

Art.nr. 157100  
 Boekenkast  
 Bookshelf  
 Bücherschrank



Lees de handleiding voordat u begint.  
 De losse onderdelen zijn niet geschikt voor kinderen onder de 3 jaar  
 Het product dient te worden geassembleerd door een volwassene,  
 alvorens door een kind gebruikt te worden.

Read the instructions before you begin.  
 The individual parts are not suitable for children under 3 years  
 The product has to be assembled by an adult,  
 before being used by a child.

Lesen Sie die Anweisungen bevor Sie beginnen.  
 Die Einzelteile sind nicht für Kinder unter 3 Jahren geeignet  
 Das Produkt soll durch ein Erwachsene zusammengebaut werden, bevor es  
 durch ein Kind verwendet werden kann.

Inhoud  
 contents  
 inhalt

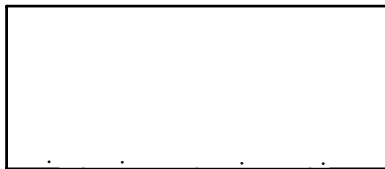

3x

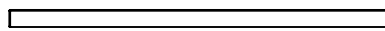

3x

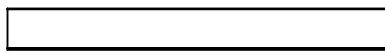

1x

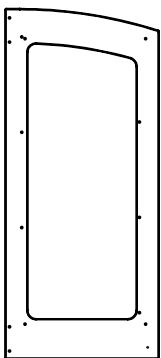

2x



1x

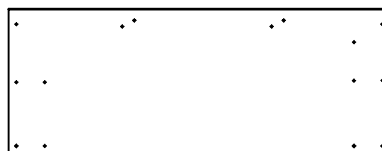

1x

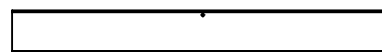

1x

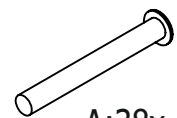

A: 38x



B: 2x



C: 16x



D: 2x



E: 4x

Optioneel  
 Optional  
 Optional



1x

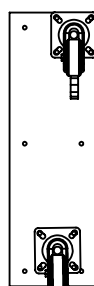

1x

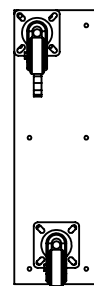

1x

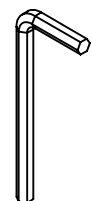

1x

1

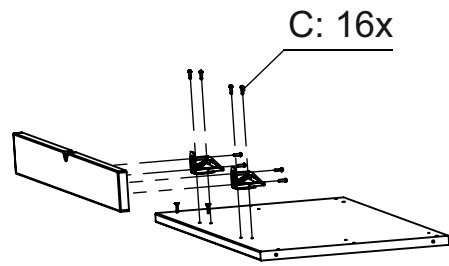

2a

Herhaal deze stap voor de andere zijkant.

Repeat this step for the other side panel.

Wiederholen Sie diesen Schritt im anderen Regal.

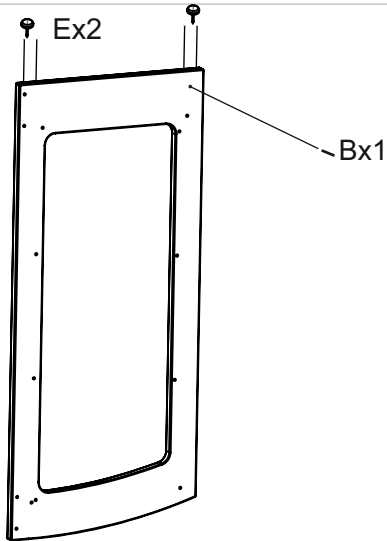

2b

ATTENTIE:  
Blokeer de wielen alvorens U aan de volgende stap begint.

ATTENTION:  
Lock the wheels before moving on to the next step.

ACHTUNG:  
Sperren Sie die Räder, bevor Sie mit dem nächsten Schritt beginnen.

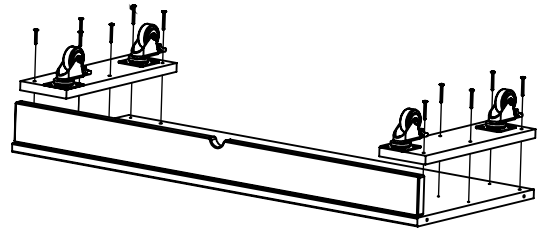

3

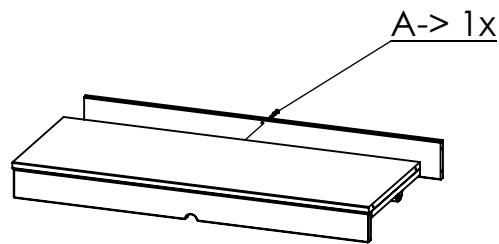

4

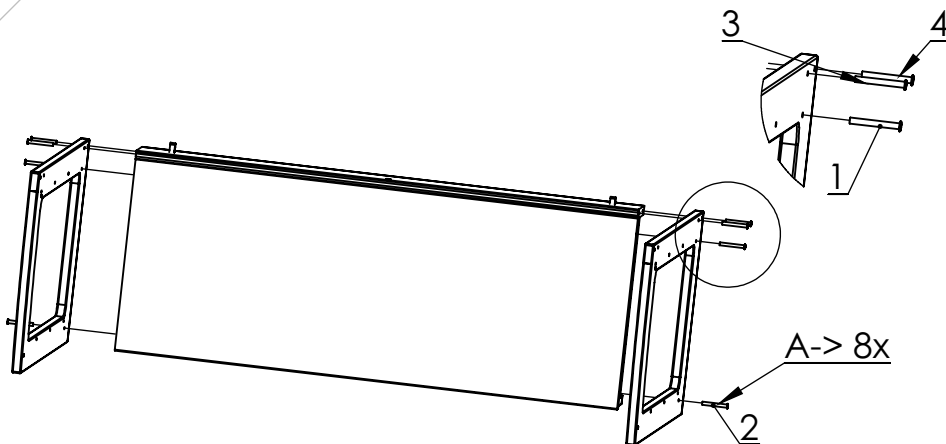

ATTENTIE:  
Voor U eigen gemak legt u de kast met de voorkant naar beneden.

ATTENTION:  
For your own comfort, set front of the cabinet face down on the working surface.

ACHTUNG:  
Platzieren Sie das Gehäuse, zu Ihrer eigenen Bequemlichkeit, mit der Vorderseite nach unten.

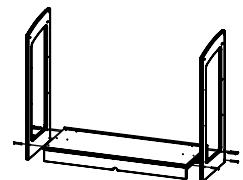

5a

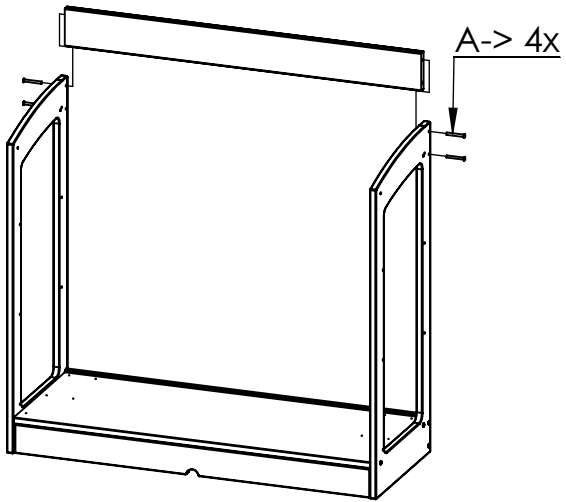

5b

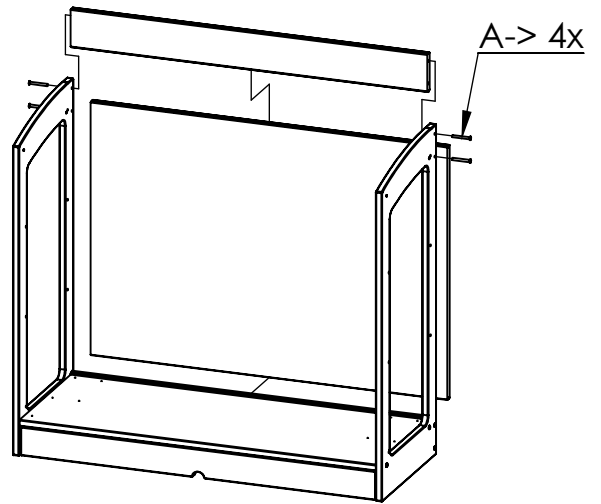

6

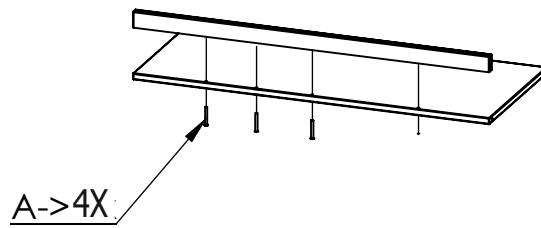

Herhaal deze stap bij de andere 2 planken

Repeat this step for the other shelves

Wiederholen Sie diesen Schritt für die anderen 2 Regale

7

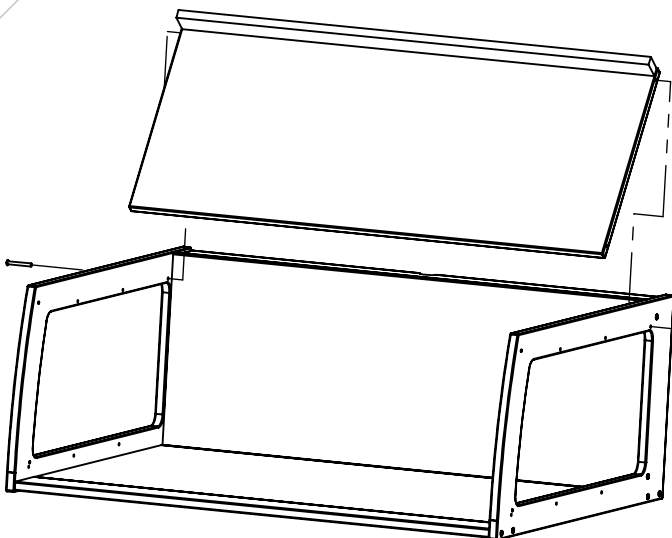

ATTENTIE:

Voor U eigen gemak legt u de kast op de achterkant.

ATTENTION:

For your own comfort, set back of the cabinet face down on the working surface.

ACHTUNG:

Platzieren Sie das Gehäuse, zu Ihrer eigenen Bequemlichkeit, mit der Achterseite nach unten.

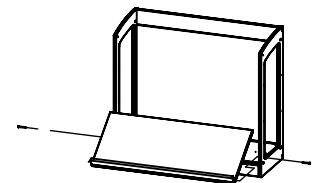

8

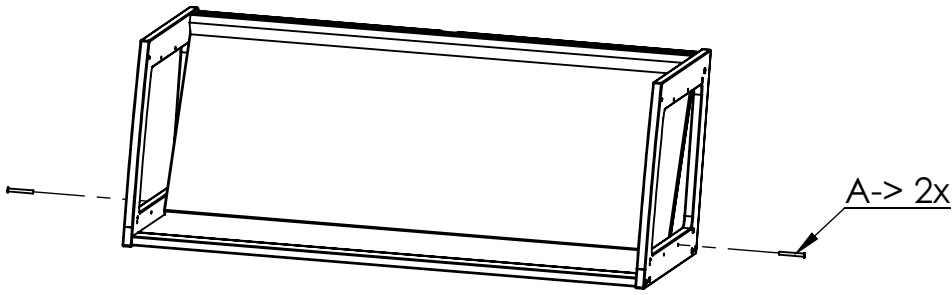

ATTENTIE:  
Voor U eigen gemak  
legt u de kast op de achterkant.  
ATTENTION:  
For your own comfort, put the  
cabinet with the back down  
on a flat surface.  
ACHTUNG:  
Platzieren Sie das Gehäuse, zu  
Ihrer eigenen Bequemlichkeit,  
mit der Achterseite nach unten.

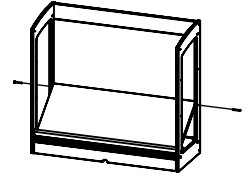

9

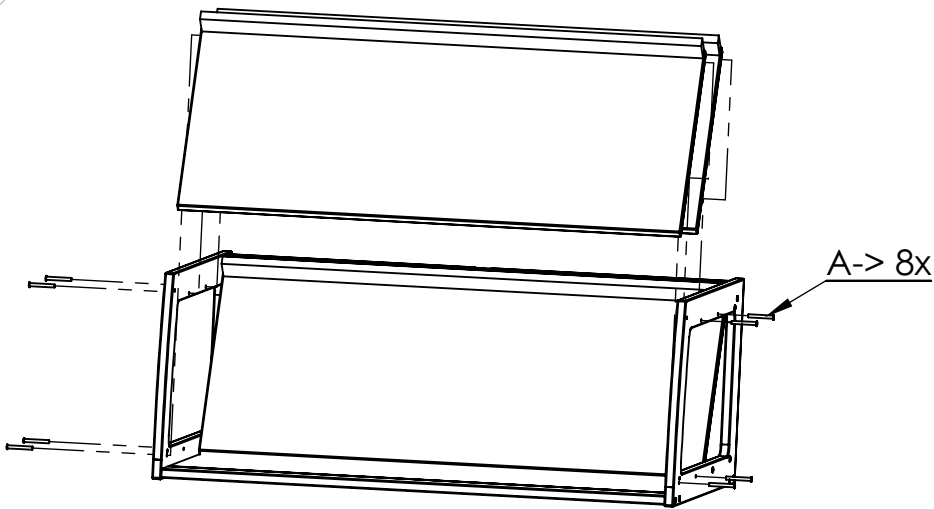

ATTENTIE:  
Voor U eigen gemak  
legt u de kast op de achterkant.  
ATTENTION:  
For your own comfort, put the  
cabinet with the back down  
on a flat surface.  
ACHTUNG:  
Platzieren Sie das Gehäuse, zu  
Ihrer eigenen Bequemlichkeit,  
mit der Achterseiten nach unten.

